

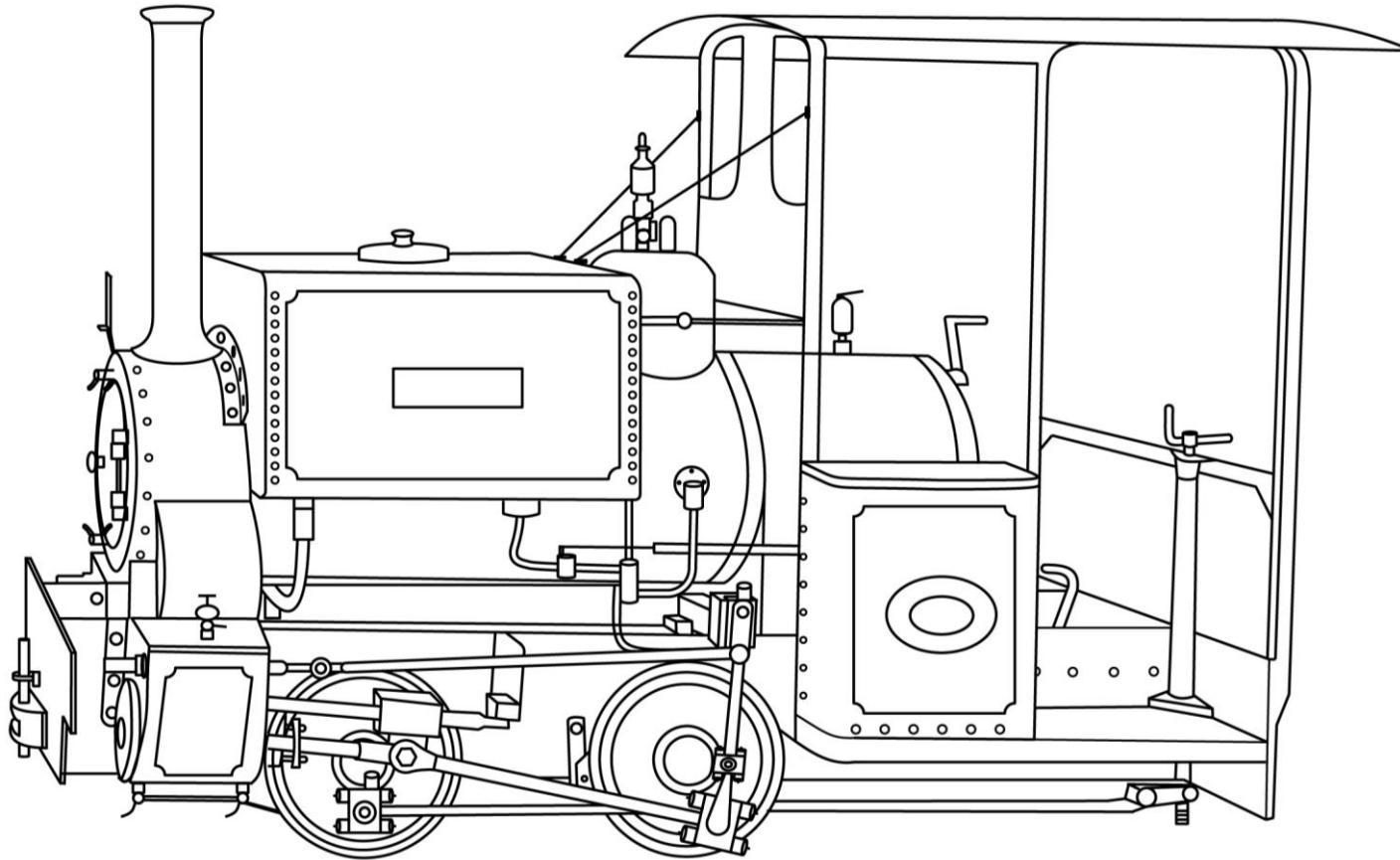

Amerton Railway



Kerr, Stuart and Company of California Works in Stoke-on-Trent were a builder of steam locomotives starting in 1881. They were a pioneer of standard designs, the Wren being one of these. In only 1930 the company closed due to poor financial decisions made by the directors. The Hunslet Engine Company bought the good will (drawings, parts etc...) of Kerr, Stuart and Company who are still trading to this day!

We have 2 wrens at Amerton. Lorna Doone was built in 1922 as one of a batch of 27 Wrens built for road construction in Essex. In 1928 she was sold to Devon County Council to work in a road stone quarry. She was saved and went to Birmingham Museum of Science and Industry. She is now on loan to Amerton Railway where we have restored her to working condition! Jennie was built as recently as 2008 by the Hunslet Engine Company, who by then were based in Tamworth! Jennie has a relaxed life at Amerton, but has travelled the country, and as far as Belgium to spread the amazing story of Amerton!